



## SH-FLOOD-8F (V2)

TWO WAY WIRELESS  
FLOOD DETECTOR



INSTRUCTION MANUAL  
Manual P/N 7103970 Rev A (DZ)

### PRODUCT FEATURES

The SH-FLOOD-8F (V2) is a two-way wireless Flood Detector designed to detect water leaks in kitchens, bathrooms, warehouses or yachts. Installation is easy and provides an early warning of developing leaks.

- Freewave2™ Two Way ISM
- GFSK with 5 frequencies & LBT
- Ultra Low current consumption
- Powered by 2 Lithium batteries 1.5V Size AA 3300mA

**Caution: Batteries non-user replaceable**

- Battery life up to 5 years
- Operating Frequencies: 868MHz / 916MHz
- Event Transmission:
  - Alarm – Water detection
  - Tamper Open/Close
  - Supervision
  - Battery status
- Bi-Color LED indications
- Up to 500m transmission range in open space
- Remotely configurable

### DETECTOR OVERVIEW

#### Front View

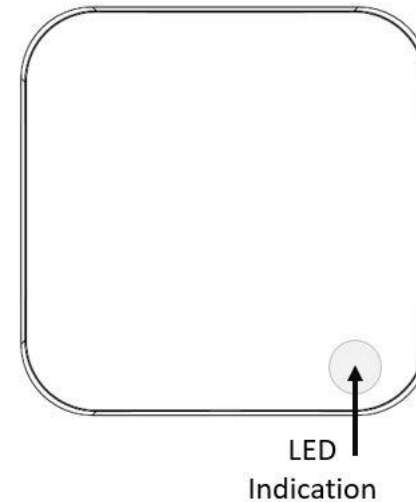

Figure 1

#### Rear View

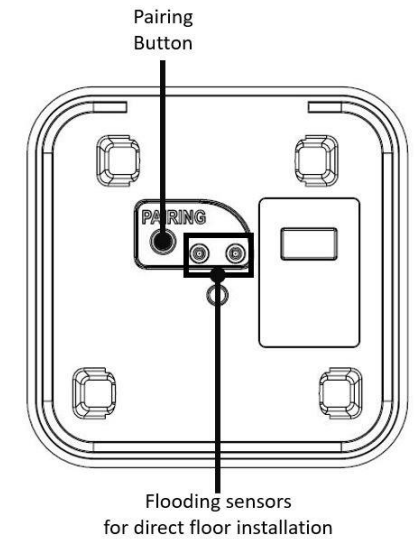

Figure 2

### BRACKET SETS

#### Default wall bracket set

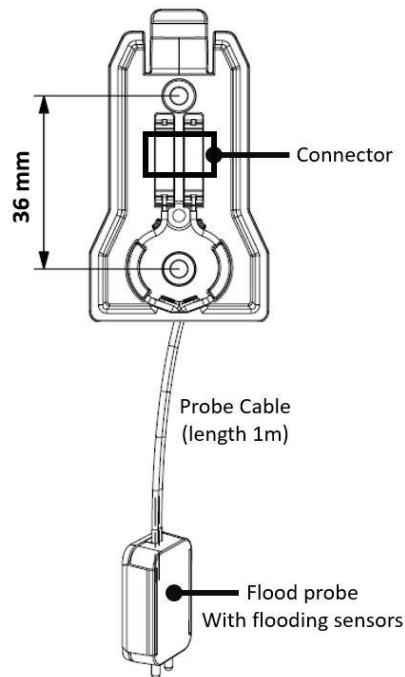
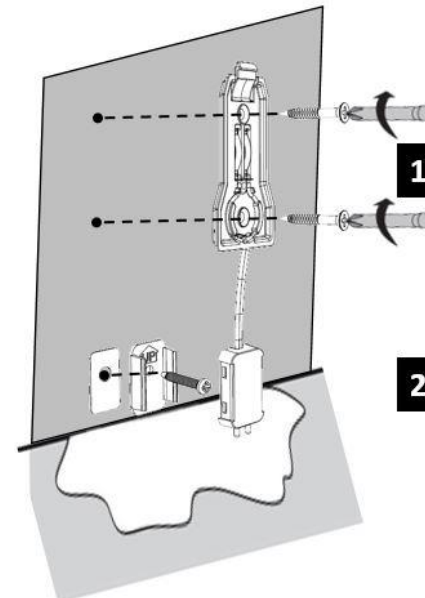

Figure 3

#### Optional wall bracket set

Figure 4

### WALL MOUNTING



1. Use supplied screw to fix the bracket on the wall
2. Use supplied screw or adhesive tape to fix the probe sensor on the wall. The fluid has to reach the two exposed Golden contacts at the bottom side of the sensor in order to give an alarm.

### LEARNING PROCESS

For pairing process, please refer to your control panel instructions.

To pair your device with Shepherd™ panel, please proceed as follows:

1. Enter in installing mode via the "Installer Webpage"
2. Go to "Zones" and select the zone you want to learn
3. Enter the unique radio device ID, and then send the configuration to the control panel
4. Press the "Pairing" button located at the back of the device (figure 2) and wait until Green/Red LED stops blinking.
5. When registration process is successfully completed, the Green LED will constantly light ON for 3 seconds and then turn OFF.

The device should register to the Control Panel and the zone is automatically defined as "24h water detection".

#### Transmission Test

Make a momentary short between the two golden contacts pins of the sensor. the Flood alarm should appear on the control panel display

**Zone # X Open**

## DETECTOR INSTALLATION OPTIONS

On wall:

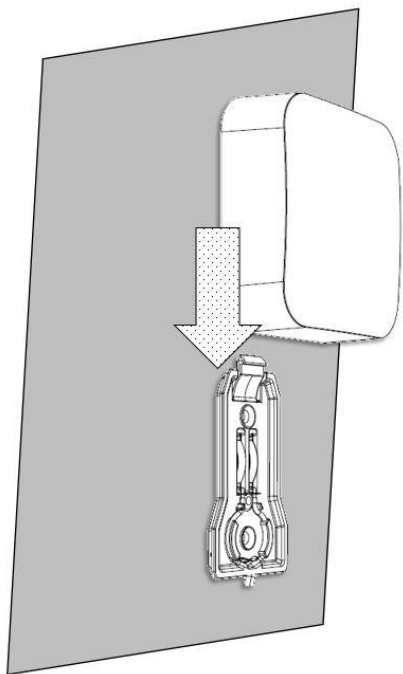

Figure 6

Gently slide in the detector into the bracket

Direct on the floor:

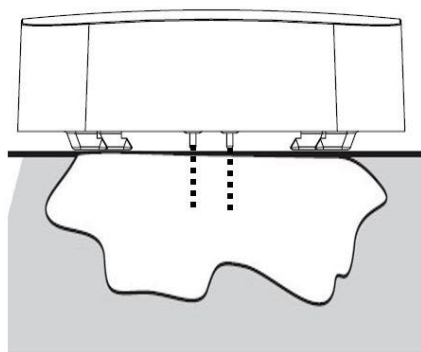

Figure 7

The SH-FLOOD is designed in a way that it can be operated without mounting it.

Put it without bracket set directly on the floor.

The sensor has to be put on the floor or surface, in close proximity to potential water leakage points and in a way that when there is a leak, water will not drop directly on the sensors.

## SPECIFICATION

Detection Method	Flooding Sensors
Communication Protocol	Freewave2™ Two Way ISM GFSK with 5 frequencies & LBT
Operating Frequencies	868MHz / 916MHz
Identification	Unique ID serial number – 24 bit
Events Transmission	Alarm, Tamper, Supervision, Low Bat, Keep Alive.
Supervision Time	7 min by default (configurable between 1 to 30 min)
Transmission Range	500m in open space
Battery	2 Lithium batteries AA 1.5V Type L92
Battery life	Up to 5 years
Current Consumptions	Standby ~5 µA Receive mode ~24 mA Transmit mode ~50 mA Transmit power ~12dBm Low Bat 3V Cut Off 2.7V
Tamper Switch	Front Cover Removal
Operating temperature	-10°C to +55°C
Dimensions	60mm x 20mm
Weight (incl. battery)	50gr.

## STANDARDS APPROVALS

The SH-FLOOD conforms to the essential requirements set out by:

- RED directive: 2014/53/EU
- EMC directive: 2014/30/EU
- Low Voltage directive: 2014/35/EU

Harmonized Standards applicable to this products are:

- EN 300 220-1
- EN 300 220-2
- EN 50130-4
- EN 61000-6-3
- EN 301 489-1
- EN 301 489-3
- EN 62368-1

Security Grade2, Environmental Class II  
Power supply Type C



## WARRANTY POLICY CERTIFICATE

Crow warrants these products to be free from defects in materials and workmanship under normal use and service for a period of 24 months from the last day of the week and year whose numbers are printed on the printed circuit board inside these products.

Subject to the provisions of this Warranty Certificate, during the Warranty Period, Crow undertakes, at its sole discretion and subject to Crow's procedures, as such procedures are from time to time, to repair or replace, free of charge for materials and/or labor, products proved to be defective in materials or workmanship under normal use and service. Repaired products shall be warranted for the remainder of the original Warranty Period.

All transportation costs and in-transit risk of loss or damage related, directly or indirectly, to products returned to Crow for repair or replacement shall be borne solely by the Purchaser.

This Warranty Certificate does not cover products that is defective (or shall become defective) due to: (a) alteration of the products (or any part thereof) by anyone other than Crow; (b) accident, abuse, negligence, or improper maintenance; (c) failure caused by a product which Crow did not provide; (d) failure caused by software or hardware which Crow did not provide; (e) use or storage other than in accordance with Crow's specified operating and storage instructions.

There are no warranties, expressed or implied, of merchantability or fitness of the products for a particular purpose or otherwise, which extend beyond the description on the face hereof.

This limited Warranty Certificate is the Purchaser's sole and exclusive remedy against Crow and Crow's sole and exclusive liability toward the Purchaser in connection with the products, including without limitation - for defects or malfunctions of the products. This Warranty Certificate replaces all other warranties and liabilities, whether oral, written, (non-mandatory) statutory, contractual, in tort or otherwise.

In no case shall Crow be liable to anyone for any consequential or incidental damages (inclusive of loss of profit, and whether occasioned by negligence of the Crow or any third party on its behalf) for breach of this or any other warranty, expressed or implied, or upon any other basis of liability whatsoever.

Crow does not represent that these products can not be compromised or circumvented; that these products will prevent any person injury or property loss or damage by burglary, robbery, fire or otherwise; or that these products will in all cases provide adequate warning or protection.

Purchaser understands that a properly installed and maintained product may in some cases reduce the risk of burglary, fire, robbery or other events occurring without providing an alarm, but it is not insurance or a guarantee that such will not occur or that there will be no personal injury or property loss or damage as a result. Consequently, Crow shall have no liability for any personal injury, property damage or any other loss based on claim that these products failed to give any warning. If Crow is held liable, whether directly or indirectly, for any loss or damage with regards to these products, regardless of cause or origin, Crow's maximum liability shall not in any case exceed the purchase price of these products, which shall be the complete and exclusive remedy against Crow.



sales@crow.co.il  
support@crow.co.il

[www.thecrowgroup.com](http://www.thecrowgroup.com)

These instructions supersede all previous issues in circulation prior to April 2019