

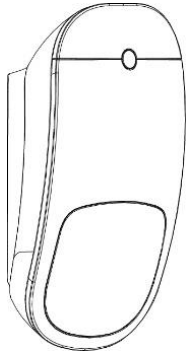

SH-PIR-8F (V3)

TWO WAY WIRELESS
PIR MOTION DETECTOR



Pet Immunity
Up to 25kgs

INSTRUCTION MANUAL

PRODUCT FEATURES

The SH-PIR is an advanced, fully supervised low-current wireless motion detector that includes a FW2 transceiver for reliable system operation combined with the most advanced Mirror Optics detection method.

- Freewave2™ Two Way ISM
- GFSK with 5 frequencies & LBT.
- Ultra Low current consumption.
- Immunity to attenuation feature
- Powered by a 3V Type CR123A Lithium battery.
- Motion Detection up to 12 meters
- Battery life up to 5 years.
- Operating Frequencies: 868MHz / 916MHz
- Event Transmission:
 - Alarm
 - Tamper Open/Close
 - Supervision
 - Battery status
- Bi-Color LED indications
- Up to 500m transmission range in open space.
- Remotely configurable.
- Pet immune up to 25kgs.

DETECTOR OPENING

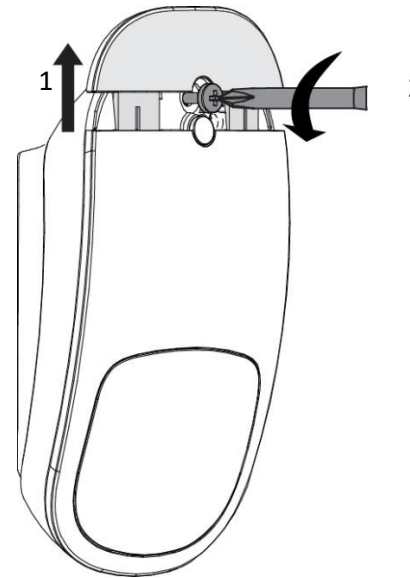

Figure 1

BRACKET REMOVAL

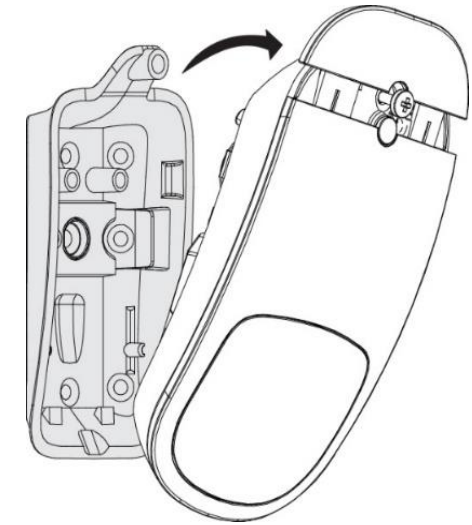

Figure 2

BATTERY INSERTION

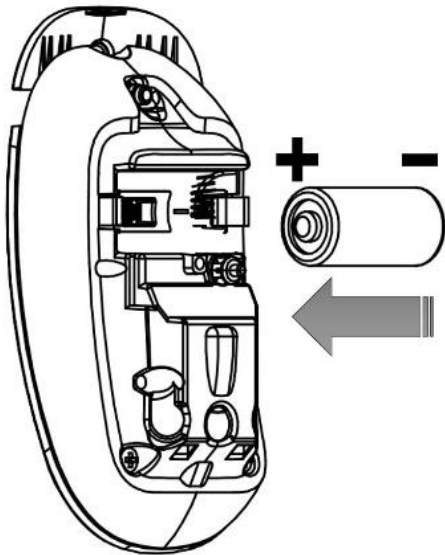

Figure 3

The battery can be replaced by the user
Battery type: 3V Type CR123A Lithium

DETECTOR MOUNTING

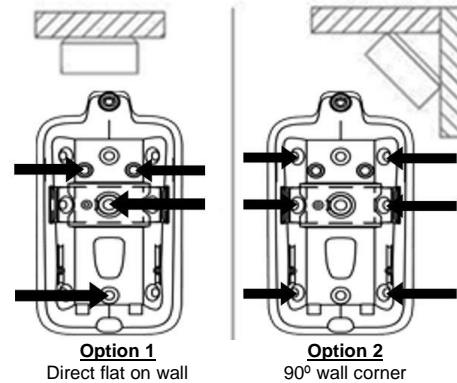
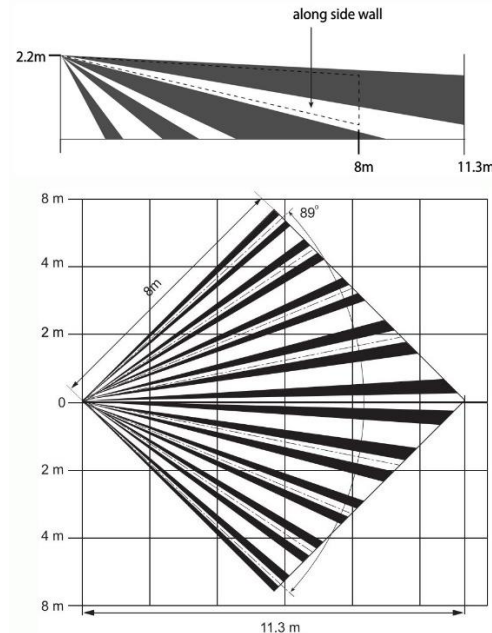

Figure 4

Avoid the following locations:

- Facing direct sunlight.
- Facing areas that may change temperature rapidly.
- Areas where there are air ducts or substantial airflows.

DETECTION COVERAGE



Recommended mounting height – 2.1m to 2.3m

LEARNING PROCESS

For pairing process, please refer to your control panel instructions.

To pair your device with Shepherd™ panel, please proceed as follows:

1. Enter in installing mode via the "Installer Webpage"
2. Go to "Zones" and select the zone # you want to learn
3. Add Zone - (Reminder: insert Link Type "ISM", device's ID, Device Type "Infrared motion detector".)
4. Set the detector configuration: supervision time. Pulse count...and etc. and save configuration.
5. Place a battery as instructed in Figure 3 and wait until the Red LED stops blinking.
6. The device should register to the Control Panel.
7. When registration process is successfully completed, the Green LED will constantly light ON for 3 seconds and then turn OFF.
8. If Green LED continues flashing more than 5 minutes and stopped. Please check PIR settings details, remove batteries and repeat step 4,5,6

DETECTOR TESTING

After pairing and installing the detector, we recommend performing walk and transmission tests.

Motion Transmission Test

Walk crossing in front of the detector from one side to the other will cause motion alert transmissions. Verify receiving the indication on your control panel. Pay attention that due to APS feature it is required waiting 30 seconds between 2 consecutive indications.

Walk Test

- Activate walk test mode via Web Installer (in the overview level), for walk test institutions use Panel manual.
- Make few walk crossing in front of the detector and see results in Overview display.

Tamper Transmission Test

Changing the tamper switch state (by attaching / removing the device to / from the Bracket) will cause tamper transmissions.

EVENT TRANSMISSION

SUPERVISION – A periodical transmission (configurable) indicating detector's presence.

ALARM – Alarm transmission triggered by the device indicating Motion detection. The Red LED will blink once.

LOW BAT – Whenever the battery reaches the low level (2.8V), a Battery Low signal will be sent. When Battery level drops below Cut Off level (2.6V) the device will stop functioning and the Red LED will blink for 10 seconds and then turned Off.

TAMPER – Whenever the cover is removed from Bracket or the device is tear off from the wall, a message will be transmitted with "Tamper ON" signal. When cover will be returned a "Tamper OFF" signal will be transmitted.

BATTERY REPLACEMENT

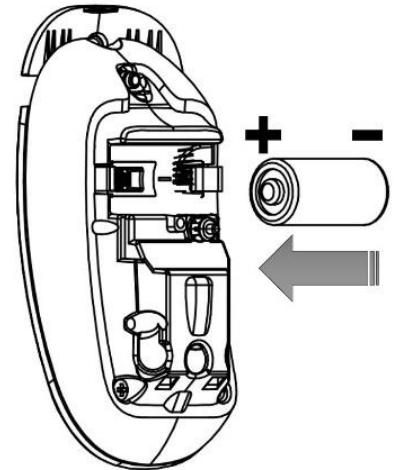

Figure 5

The battery must be replaced by 3V Lithium

Models such as
1. VARTA CR123A
2. GP CR123A

CAUTION

RISK OF EXPLOSION
IF BATTERY IS REPLACED BY DIFFERENT TYPE / MODEL.

DISPOSE USED BATTERIES
ACCORDING TO ITS INSTRUCTIONS

SPECIFICATION

Detection Method	PYRO Element
Communication Protocol	Freewave2™ Two Way ISM GFSK with 5 frequencies & LBT
Operating Frequencies	868-869MHz or 916-917MHz
Identification	Unique ID serial number – 24 bit
Events Transmission	Alarm, Tamper, Supervision, Low Bat, Keep Alive.
Supervision Time	7 min by default (configurable between 1 to 30 min)
Transmission Range	500m in open space
Battery	3V Type CR123A Lithium
Battery life	Up to 5 years
Current Consumptions	Standby ~11 µA Receive mode ~24 mA Transmit mode ~45 mA Transmit power up to 14dBm Low Bat 2.5V Restore Low Bat 2.6V Cut Off 2.6V
Tamper Switch	Front Cover and Wall Removal
Operating temperature	-10°C to +55°C
Dimensions	108mm x 58mm x 43mm
Weight (incl. battery)	90 gr.

STANDARDS APPROVALS

The SH-PIR conforms to the essential requirements set out by:

- RE directive (RED): 2014/53/EU
- EMC directive: 2014/30/EU
- Low Voltage directive: 2014/35/EU
- RoHS3 directive: 2015/863/EU

Harmonized Standards applicable to this products are:

- EN 50130-4
- EN 61000-6-3
- EN 301 489-1
- EN 301 489-3
- EN 300 220-1
- EN 300 220-2
- EN 62368-1

Additional Standards and Directives applicable to this product are:

- EN 50131-1
- EN 50131-2-2
- EN 50131-6
- EN 50131-5-3
- EN 50130-5

Certification body: Kiwa Nederland B.V.
 Security Grade2, Environmental Class II
 Power supply Type C



WARRANTY POLICY CERTIFICATE

Crow warrants these products to be free from defects in materials and workmanship under normal use and service for a period of 24 months from the last day of the week and year whose numbers are printed on the printed circuit board inside these products.

Subject to the provisions of this Warranty Certificate, during the Warranty Period, Crow undertakes, at its sole discretion and subject to Crow's procedures, as such procedures are form time to time, to repair or replace, free of charge for materials and/or labor, products proved to be defective in materials or workmanship under normal use and service. Repaired products shall be warranted for the remainder of the original Warranty Period. All transportation costs and in-transit risk of loss or damage related, directly or indirectly, to products returned to Crow for repair or replacement shall be borne solely by the Purchaser.

This Warranty Certificate does not cover products that is defective (or shall become defective) due to: (a) alteration of the products (or any part thereof) by anyone other than Crow; (b) accident, abuse, negligence, or improper maintenance; (c) failure caused by a product which Crow did not provide; (d) failure caused by software or hardware which Crow did not provide; (e) use or storage other than in accordance with Crow's specified operating and storage instructions. There are no warranties, expressed or implied, of merchantability or fitness of the products for a particular purpose or otherwise, which extend beyond the description on the face hereof.

This limited Warranty Certificate is the Purchaser's sole and exclusive remedy against Crow and Crow's sole and exclusive liability toward the Purchaser in connection with the products, including without limitation - for defects or malfunctions of the products. This Warranty Certificate replaces all other warranties and liabilities, whether oral, written, (non-mandatory) statutory, contractual, in tort or otherwise. In no case shall Crow be liable to anyone for any consequential or incidental damages (inclusive of loss of profit, and whether occasioned by negligence of the Crow or any third party on its behalf) for breach of this or any other warranty, expressed or implied, or upon any other basis of liability whatsoever. Crow does not represent that these products can not be compromised or circumvented; that these products will prevent any person injury or property loss or damage by burglary, robbery, fire or otherwise; or that these products will in all cases provide adequate warning or protection.

Purchaser understands that a properly installed and maintained product may in some cases reduce the risk of burglary, fire, robbery or other events occurring without providing an alarm, but it is not insurance or a guarantee that such will not occur or that there will be no personal injury or property loss or damage as a result. Consequently, Crow shall have no liability for any personal injury; property damage or any other loss based on claim that these products failed to give any warning. If Crow is held liable, whether directly or indirectly, for any loss or damage with regards to these products, regardless of cause or origin, Crow's maximum liability shall not in any case exceed the purchase price of these products, which shall be the complete and exclusive remedy against Crow.



sales@crow.co.il
 support@crow.co.il

www.thecrowgroup.com